



17" Projective Capacitive 10pt touch screen

The ProLite T1732MSC 17" multi-touch screen is based on projected capacitive technology which thanks to a glass overlay covering the screen guarantees high durability, scratch-resistance and perfect picture performance. The touch function remains unaffected even if the glass is scratched. A solid and steady base supports the TouchScreen with an adjustable stand offering full 90 degree positioning angles. Menu Buttons are located on the side of the screen which can be locked to prevent tampering and includes a handy function to deactivate the TouchScreen for cleaning. In addition the edge-to-edge glass design creates an eye-catching finish with high light transmission guaranteeing perfect picture clarity and brilliant colours. Available in black and white.



Touch technology - Capacitive

This technology uses a sensor-grid of micro-fine wires integrated into the glass that covers the screen. Touch is detected because electrical characteristics of the sensor grid change when human finger is placed on the glass. Thanks to the glass overlay this technology is highly durable, and the touch function remains unaffected even if the glass is scratched. It offers perfect picture performance and will work with human finger (also latex gloved) and stylus-pen.



Scratch resistance

Scratch resistance is essential for touch solutions used in public places and schools. This is achieved thanks to a glass overlay covering the screen. It guarantees high durability of the touch function and even more importantly the touch function remains unaffected even if the glass is scratched.

01 DISPLAY CHARACTERISTICS

Design	Edge to edge glass
Diagonal	17", 43cm
Panel	TN LED
Native resolution	1280 x 1024 (1.3 megapixel)
Aspect ratio	5:4
Brightness	250 cd/m ² typical
Brightness	225 cd/m ² with touch
Static contrast	1 000:1 with touch
Light transmittance	90%
Response time	5ms
Viewing zone	horizontal/vertical: 160°/160°, right/left: 80°/80°, up/down: 80°/80°
Colour support	16.7mln 8bit (6bit + Hi-FRC)
Horizontal Sync	31,4 - 80KHz
Vertical Sync	56 - 75Hz
Viewable area W x H	338 x 270.5mm, 13.3 x 10.6"
Pixel pitch	0.264mm
Bezel colour and finish	white, matte

02 TOUCH

Touch technology	projective capacitive
Touch points	10 (HID, only with supported OS)
Touch method	stylus, finger, glove (latex)
Touch interface	USB
Supported operating systems	All iiyama monitors are Plug & Play and compatible with Windows and Linux. For details regarding the supported OS for the touch models, please refer to the driver instruction file available in the downloads section.

03 INTERFACES / CONNECTORS / CONTROLS

Analog signal input	VGA x1
Digital signal input	DVI x1
Audio output	Speakers 2 x 1W

04 FEATURES

Impact testing	IP54 (front)
OSD key lock	yes

05 GENERAL

OSD languages	EN, DE, FR, ES, IT, CN, JP
Control buttons	Menu, Scroll up/ Brightness, Scroll down/ Mute, Select/ Auto, Power
User controls	contrast, brightness, auto adjust, H.position, V.position, H.size, phase, OSD H.position, OSD V.position, OSD timeout, reset, input select, OSD language, colour temperature, volume, mute
Convenience	Kensington-lock™ prepared
Plug&Play	DDC2B

06 MECHANICAL

Tilt angle 90° up; 5° down

VESA mounting 100 x 100mm

Cable management system yes

07 ACCESSORIES INCLUDED

Cables power, VGA, DVI, USB, Audio

Guides quick start guide, safety guide

Other Touch Panel Driver Disk (CD-ROM)

Cable cover yes

08 POWER MANAGEMENT

Power supply unit internal

Power supply AC 100 - 240V, 50/60Hz

Power usage 25W typical, 2W stand by

09 SUSTAINABILITY

Regulations CB, CE, TÜV-Bauart, VCCI, GOST

10 DIMENSIONS / WEIGHT

Product dimensions W x H x D 387 x 342 x 202mm

Weight (without box) 5.6kg

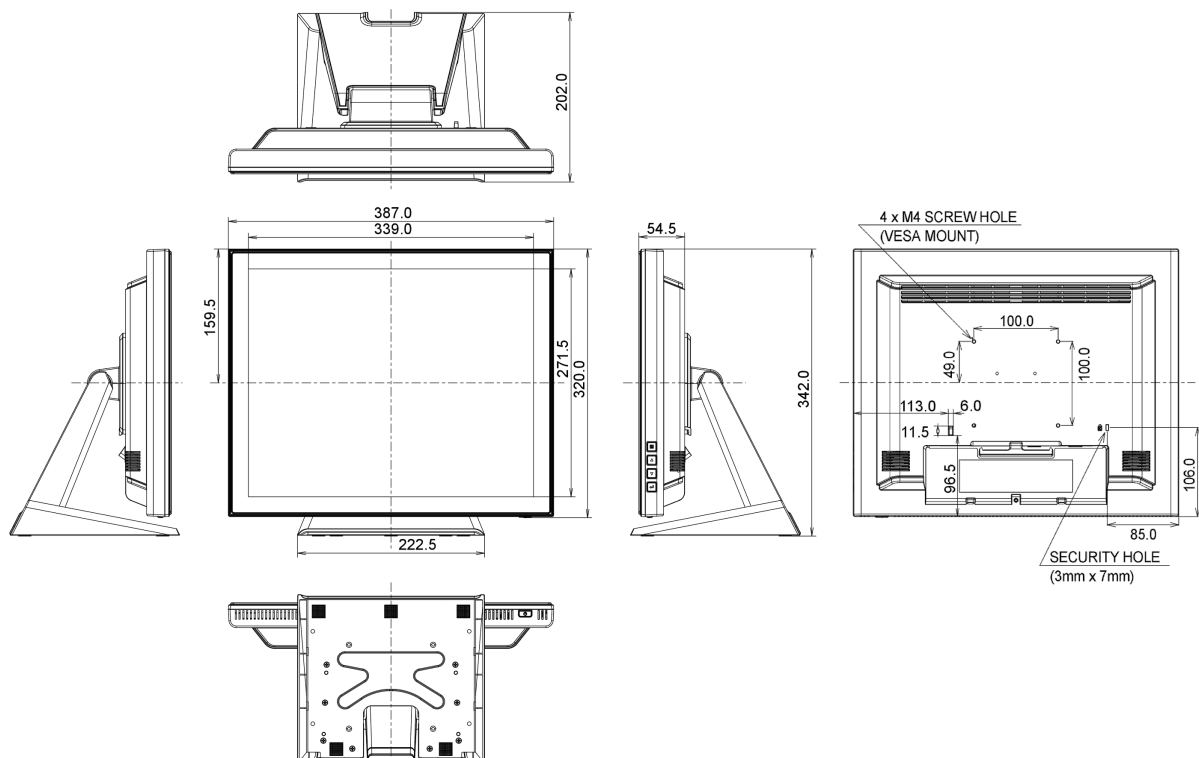

All trademarks and registered trademarks acknowledged. E & O E. Specification subject to change without notice. All LCD's comply with ISO-9241-307:2008 in connection with pixel defects.

© IYAMA CORPORATION. ALL RIGHTS RESERVED